

Blueair by BLUENIX

MODEL BSF72T-HC TOP MOUNT REACH-IN FREEZER

Sleek and durable cooling solution for
your food and beverages.



Conforms to NSF/ANSI 7(ETL)



Stainless steel cabinet construction

Stainless steel interior and exterior
(galvanized steel back & bottom).



Temperature range between -10°F ~ 5°F

Air guard on rear wall ensures proper air
circulation and cooling.



Hydrocarbon refrigerants (R-290)

Increases energy HFC refrigerants. It is
safer for the environment and does not
cause ozone depletion.



Visual and audible door open alarm

Alarm sounds when doors are not completely
closed to protect against food spoilage

**5 YEAR
WARRANTY**

PARTS & LABOR

**7 YEAR
WARRANTY**

COMPRESSORS

Blue Air has right to change specifications without further notice.

Cabinet construction

- Cyclopentane Insulation – Contains no hydro-fluorocarbons (HFCs) and is environmentally friendly.
- Epoxy coated wire shelves with adjustable shelving height.
- 4 shelves per compartment.
- Six (6) casters which two (2) have front brakes

Refrigeration

- Self-contained system, bottom mounted compressor. Electrodeposition coated evaporator increases performance by maintaining the heat transfer rates over the life of the evaporator and reducing potential corrosion.
- Rear mounted condensation pan.
- Designed to prevent water overflow and increase ventilation.
- Innovative hot gas frame heating system reduces condensation and increases energy.

Front view

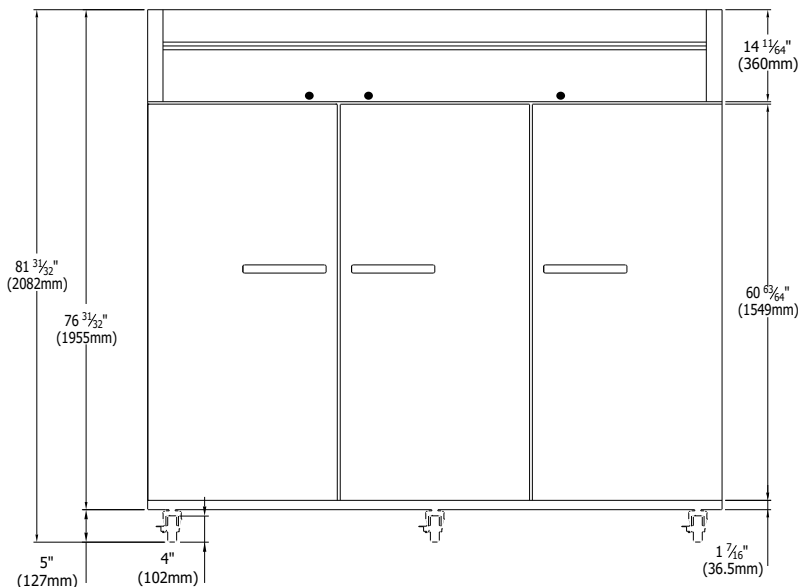

Side view

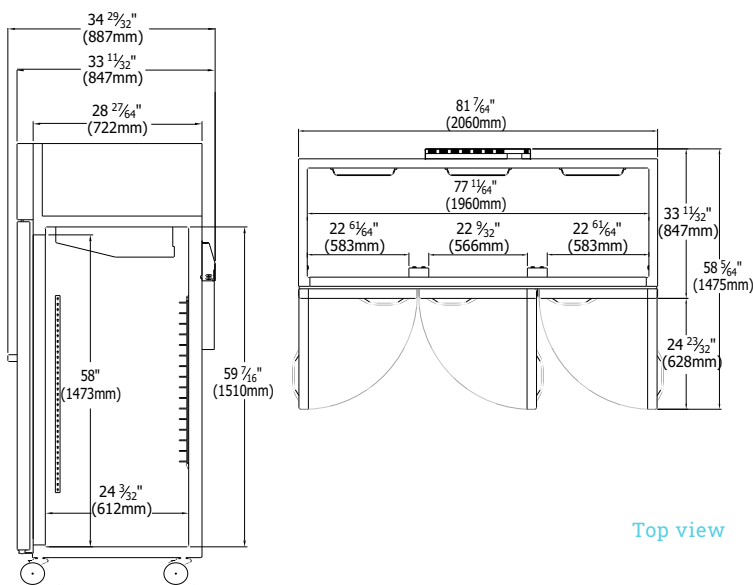

Top view

MODEL BSF72T-HC

TOP MOUNT REACH-IN FREEZER

Cabinet Dimensions (inches/mm)

L	D	H
81 7/64" 2060mm	33 11/32" 847mm	82 7/8" 2105mm

Weight (lbs/kg)

Net Weight 569 lbs 258 kg	Ship Weight 606 lbs 275 kg
---------------------------------	----------------------------------

Doors

- Self-closing doors (doors close at 90° or less)
- Automatic hold open door feature at 110°.
- Durable door gasket with easy replacement.
- Lifetime guaranteed heavy duty all metal door handles. (Ni-Cr Plated)
- Door designed to open easily.
- Doors built with pressure and with pressure relievers to eliminate vacuum pressure.
- Standard door locks.

Design & Features

- Self-diagnostic digital temperature control & monitor system.
- Digital display allows for easy monitoring.
- Digital controls include manual defrost for easy maintenance.
- Rounded corner design gives a stylish appearance and reduces chances of injury.

Optional Features & Accessories

- 2.5" diameter casters available.
- 6" adjustable legs available.
- Additional shelves are available.

Doors	3
Capacity Cu.Ft.	72
Shelves	12
Refrigerant	R-290
Temperature Range	-10°F ~ 5°F
Easy Maintenance	Sliding Condensing Unit
Connection	9.8 ft long (3m) flexible three wire cord with modeled plug
Lighting	LED Interior lighting
HP	1/2
Voltage	115V/60Hz
Amps	5.5
NEMA Config.	NEMA 5-15



• This product may expose you to chemicals including Diisononyl Phthalate (DINP), which is known to the State of California to cause cancer. For more information go to www.P65Warnings.ca.gov.

• Ce produit peut vous exposer à des agents chimiques incluant le Diisononyl Phthalate (DINP), reconnu par l'Etat de Californie comme causant le cancer. Pour de plus amples renseignements, consulter le site www.P65Warnings.ca.gov.

